

“Dear Mr/Mrs customer name,”
Discover ATOS Q with GOM
Inspect Suite, the reliable and
versatile 3D scanner for
industrial use.

START HERE



Tecnologías
Computarizadas para
Manufactura, S.A. de
C.V.

Mirlo #1125 Colonia
Morelos, Guadalajara,
Jalisco.
3389950826

Part of #HandsOnMetrology





Quality starts with a Q.

ATOS Q.





[Intro](#)

[Highlights](#)

[GOM Inspect Suite](#)

[Features](#)

[Series](#)

[Technical Data](#)

[Contact](#)

[Click to navigate](#)





The reliable high performer of industrial 3D scanning

Mobile, versatile and precise: ATOS Q is ready for your shop floor. Designed as a flexible 3D scanner for complex measurement and inspection tasks, it meets high metrological demands for many industries. In combination with GOM Inspect Suite, it's a fast, compact and simple-to-operate optical 3D measuring system with real ATOS DNA.



Designed for industry use

ATOS Q delivers fully traceable measurement results even under harsh conditions. The optical and electronic systems of the robust scanner are dustproof and splashproof – making it ideally suited for taking a project from the measuring room to production.

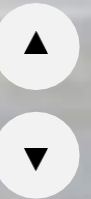

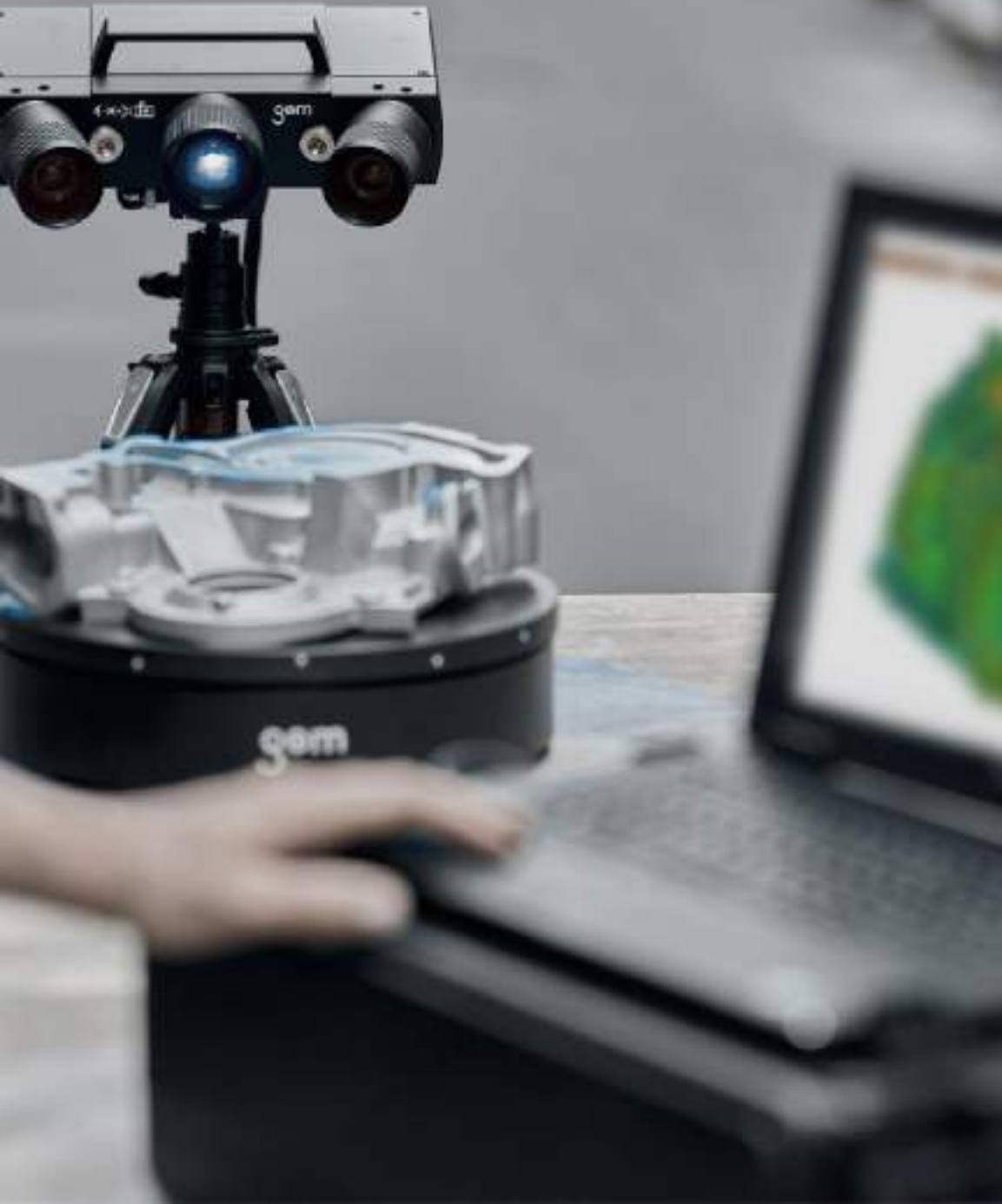

Packed with cutting-edge technology

ATOS Q captures quality information fast and with a high degree of detail. From its Triple Scan Principle to its Blue Light Equalizer, it improves your product quality, e.g. with precise digital twins and detailed 3D data for comprehensive quality analysis.



Fast results, exceptional performance

ATOS Q impresses with fast data processing. It enables high-speed fringe projection and delivers high-quality information in reduced measuring time. Industrial ports with fiber optic cables and robust plug-in connections allow for high data throughput.





Making quality visible

GOM Inspect Suite is the established standard in 3D metrology. Use this all-in-one solution for simple or complex inspection tasks throughout your entire inspection process — from scanning, mesh editing and CAD import to trend analyses, digital assembly or proprietary inspection. A software to simplify and speed up your workflow.

[DOWNLOAD FOR FREE](#)[LEARN MORE](#)

[Click to visit the HandsOnMetrology website](#)



For fast coverage:

Triple Scan Principle

ATOS Q comes with a Triple Scan Principle. The 3-in-1 sensor concept captures three different views in one measurement – ideal for measuring reflective surfaces and objects with dents.

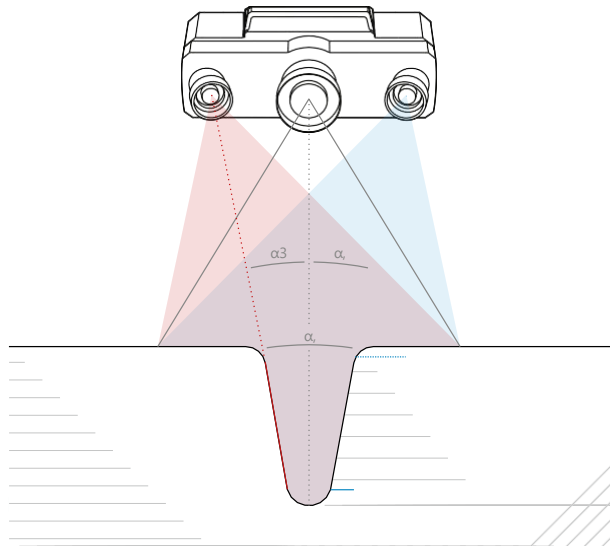

For lowest noise level:

Blue Light Equalizer

The Blue Light Equalizer enables high-speed fringe projection and is so powerful that even on uncooperative surfaces short measuring times can be achieved. It increases the brightness of the light source and transfers uniform, speckle-free light to the projection unit.

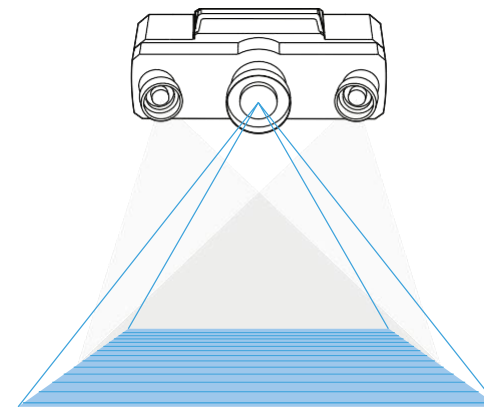



A versatile
system ready for your
shop floor

The compact ATOS Q sensor is highly versatile: It handles complex measurement and inspection tasks in manual and semi-automated or fully automated operation.

Manual

Due to its weight of only 4 kg and its compact design, ATOS Q can be easily moved. Mounted on a tripod, it's suitable for the measuring room and for mobile use in production.

Semi-automated

In combination with a tripod or desk stand and the rotating GOM ROT 350 scanning table or a motorization kit, ATOS Q may also be used for semi-automated operation.

Automated

ATOS Q is also available as a fully automated system for serial quality control with high throughput in ATOS ScanBox or with GOM ScanCobot. For more information: gom.com





Shaping quality with multiple measuring volumes

The interchangeable lenses of ATOS Q ensure high-precision measurements of small to medium-sized parts. Changing from the smallest to the largest measuring volume is easy thanks to the fixed camera position.

ATOS Q assures quality

- for additively manufactured parts
- for plastic and injection-molded parts
- in sand casting, pressure die casting and investment casting processes
- on punching, bending, drawing, pressing and forming process chains



One series, two versions

The 3D scanner ATOS Q is available in the 12M and 8M versions. The sensors capture up to 2×12 million or 2×8 million coordinate points during scanning. The precision, the resolution and the size of the measuring area are freely definable.



Technical Data

ATOS Q

Type / ATOS Q 8M

Light Source	LED
Points per scan	8 million
Measuring area (mm²)	100 x 70 – 500 x 370
Point distance (mm)	0.04 – 0.15
Working distance (mm)	490
Weight	approx. 4 kg
Dimensions	approx. 340 mm x 240 mm x 83 mm
Cable length	10 m fiber optic cable
Operating system	Windows 10
Measuring volumes	100, 170, 270, 350, 500

Type / ATOS Q 12M

Light Source	LED
Points per scan	12 million
Measuring area (mm²)	100 x 70 – 500 x 370
Point distance (mm)	0.03 – 0.12
Working distance (mm)	490
Weight	approx. 4 kg
Dimensions	approx. 340 mm x 240 mm x 83 mm
Cable length	10 m fiber optic cable
Operating system	Windows 10
Measuring volumes	100, 170, 270, 350, 500



Contact us



**Tecnologías
Computarizadas para
Manufactura, S.A. de C.V.**

Mirlo #1125, Colonia: Morelos, Guadalajara, Jalisco.

Type in your email

3389950826

#HandsOnMetrology partner





GOM GmbH
a ZEISS company

Schmitzstraße 2
38122 Braunschweig
Germany
Tel: +49 531 390290
info@gom.com

